

# VPR-200 SERIES D2 VIDEO RECORDERS



**CDP**<sup>™</sup>  
COMPOSITE  
DIGITAL

**AMPEX**

# FINALLY! A D2 MACHINE THAT MAKES *BUSINESS* SENSE.

**I**t's clear that broadcasters need superior performance from a video recorder, but some manufacturers have overlooked the fact that return on investment is often just as important. This new brace of D2 recorders from Ampex deliver both exceptional performance *and* an excellent return on investment. Here's how.

First, you have a choice between the VPR-250 that accepts 32 and 94 minute cassettes, or the VPR-200 that accepts the 32, 94, and 208 minute cassettes. This way, you needn't pay more than your application requires.

Then, of course, there's that famous Ampex durability. You probably amortize your video recorders over 5 or 7 years, but these recorders are built to be around for much longer than that—you're not going to find any "bent metal" here!

Precision milled castings and pre-aligned guide assemblies not only give you dependable

long life, but also low maintenance costs. We also designed in features like replaceable heads that cut maintenance costs and reduce down-time.

And if your facility has, or will have, our ACR-225 Automated Cassette Recorder, the heads and many of the PC boards are identical to those in the Ampex ACR-225. And most of the operational and maintenance training requirements are the same, too.

**Streamlined control functions reduce the cost of operator training, and the cost of operational errors.**

Operator training, and operator errors cost you thousands of dollars every year. Operators are "at home" with these new machines almost immediately because straight forward setup selections, instead of confusing sub-menus, make their job simple. For example, a *system setup* button displays the current list of setup parameters and their status, and the shuttle knob allows the operator to walk through each parameter and make changes if desired. And for fast on-air playback, the optional RCP-200 *remote*

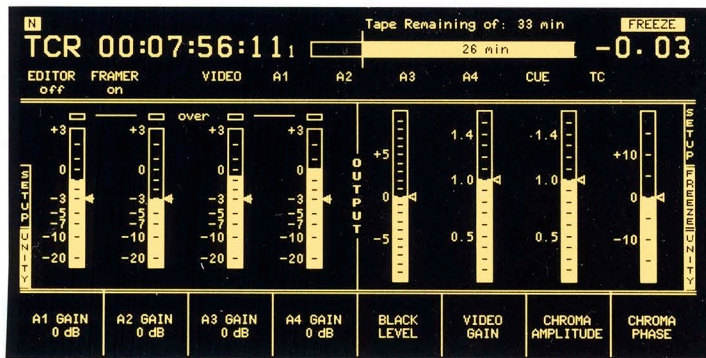

Separate input and output menus put all operator controls and level indicators for simple recording or playback on a single screen.

Replaceable heads mean less down-time and lower service costs. The heads in a VPR-200 Series machine can be replaced on-site in about five minutes.

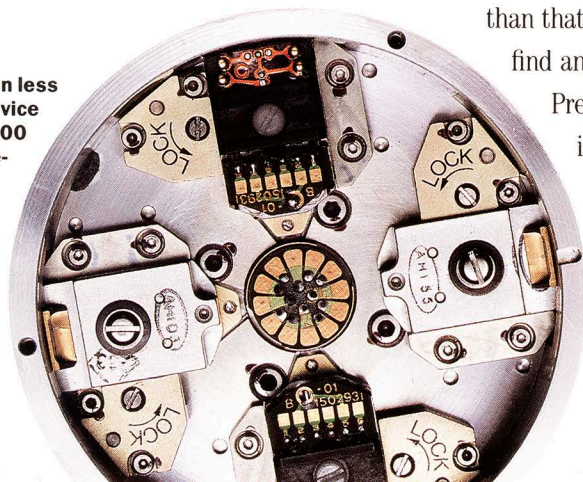





**Time code information, error messages, even audio level bargraphs can be displayed over a separate video output, making it easy to remote both record and playback control. And with the RCP-200 remote control panel, it's fast and easy to make operational adjustments.**

control panel puts basic level adjustments for simple record/play applications at the monitor rack... at the master control station... wherever you can use them best!

To allow your staff to make a fast diagnosis when problems arise, on-board diagnostics (including on-board signature analysis implemented with Ampex designed proprietary ASICs) continually monitors machine operation and reports status.

**Superior signal and transport performance.**

All D-2 recorders won't give you the same results! The VPR-200 Series will improve your on-air video and audio quality today, and give you some room for the future. To optimize analog performance, extremely high quality D/A and A/D converters are employed, with minimal analog circuitry. In fact, most of the signal processing circuitry is from our famous Zeus™ Advanced Video Processor. That means no-bounce, no-blur slow motion, freeze-frame capabilities, and Multi-Gen Setup features are standard. Of

course, in the digital domain, endless dupes can be made with no degradation whatsoever.

This high quality signal performance is teamed with a transport that is loaded with engineering innovations that translate directly to cost savings for your facility. One of our customers points out, "When you can search a minute in a second and stop on a dime, you know that's going to save time and money." High speed (60x play) search and shuttle speeds, plus air lubricated tape guides to reduce tape damage and tape costs are obvious advantages of the VPR-200 Series. But there are also equally beneficial design innovations that aren't quite so evident at first glance.

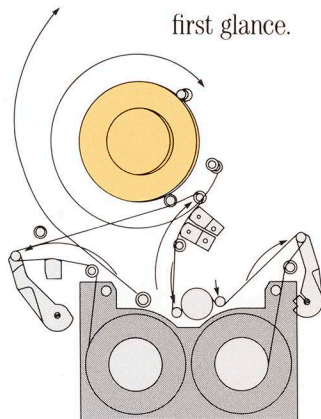

**A coplanar threading scheme allows cueing and shuttling with no tape contact at the rotary heads—reduces tape wear, and scanner wear while rewinding.**

For example, the 200 and 250 utilize a two step threading process that ensures gentle tape handling and at the same time reduces both recorder head and tape wear. In the *coplanar mode*, the tape is in contact with the time-code, cue, and control track heads only. This allows shuttling and cueing without contact with the rotary heads. Then, in the *helical thread mode*, the tape is wrapped around the scanner for record and play. And to eliminate the confusion of pre-roll timing, and to give you increased flexibility during on-air use, the transport delivers virtually instant lock up—a must for live operation.

**Read-before-write and on-board speakers are just two of the ways the 200 Series reduces equipment required, and saves time.**

With the VPR-200 Series' read-before-write feature, simple effects, such as adding a key, can now be done with a single pass on one video recorder which acts as both the record and playback machines. You can also now do sophisticated audio

playback and take advantage of the excellent audio quality available with the D-2 format.

On board speakers reduce equipment costs even more, save rack space, and make installation easier.

**Changes? Use program compression!**

The VPR-200 Series are the only machines designed especially for broadcast that make it easy to change pro-

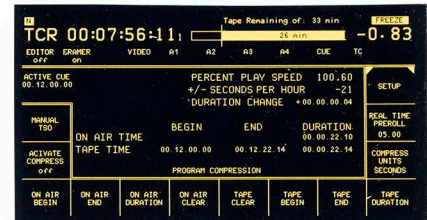

**Program compression is made simple using this menu. The operator directly enters the desired compression in terms of seconds per hour, and the machine does the rest!**

gram length. And this system does all the math for you! All you have to do is enter the program length you need and the machine does the rest—no bouncing, no blurring of the picture, and all four digital audio channels are fully recovered! Of course, both the 200 and 250 are capable of fast and easy interface to outboard pitch correction devices.

## THE FLEXIBILITY OF ALL 3 CASSETTE SIZES

The VPR-200's ability to handle the 208 minute cassette makes it ideally suited for record and playback of movie-length material, while the 32 and 94 minute cassettes offer full flexibility for spots and sports. An added benefit is that Ampex D2 equipment and Ampex 319 tape were designed together, to work together.

**Ampex 319 cassettes use a high coercivity metal particle tape to meet the rigorous specifications of the D2 format, and feature a double door mechanism to protect the tape when the cassette is not in use.**

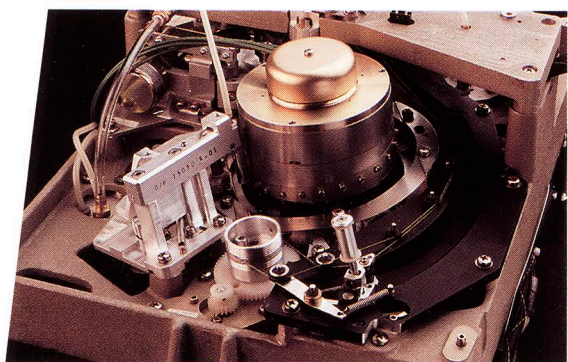

**The VPR-200 Series' rugged construction uses precision milled castings to ensure a long, dependable life and low maintenance costs.**





The VPR-200 Series' control panel is simple to learn and easy to operate, reducing learning costs and errors. For example, all machine setups are clearly displayed and easily changed without the use of cumbersome sub-menus. Set up menu report status at a glance, and make changing machine configurations intuitive instead of confusing. Setups and timing for various applications can be stored in memory for fast reconfiguration.

# THE VPR-200 SERIES D2 RECORDER



FOR INFORMATION ON AMPEX BROADCAST VIDEO PRODUCTS CONTACT THE VIDEO SALES MANAGER NEAREST YOU.

CALIFORNIA (415) 367-2202 Redwood City (818) 365-8627 San Fernando	ILLINOIS (708) 590-5100 Rolling Meadows	TEXAS (214) 960-1162 Carrollton	BRAZIL (021) 541-4137 Rio de Janeiro	W. GERMANY (069) 60580 Frankfurt (Main)	MEXICO 554-9255 Mexico, D.F.	SWEDEN 08/28 29 10 Sundbyberg
COLORADO (303) 279-1300 Golden	MARYLAND (301) 530-8800 Bethesda	WASHINGTON (206) 251-8682 Kent	CANADA (416) 821-8840 Mississauga, Ont.	HONG KONG (852) 7361866 Kowloon	NETHERLANDS 030-612921 Utrecht	SWITZERLAND (037) 21.86.86 Fribourg
GEORGIA (404) 491-7112 Atlanta	MASSACHUSETTS (617) 932-6201 Woburn	AUSTRALIA (008) 023124 North Ryde, NSW	COLOMBIA 236-4659 Bogota	ITALY (06) 500971 Rome	NEW ZEALAND (9) 275-3085 Auckland	UNITED KINGDOM (0734) 875200 Reading, Berks.
	NEW JERSEY (201) 825-9600 Allendale (212) 947-8633 New York	BELGIUM 067/214921 Nivelles	FRANCE (01) 4270-5500 Paris	JAPAN (03) 767-4521/2/3 Tokyo	SPAIN (91) 241-0919 Madrid	VENEZUELA 793-1436 Caracas



# VPR-200 D2 FORMAT COMPOSITE DIGITAL RECORDER

## General

The VPR-200 recorder is a D2 format composite digital machine especially adapted for the various VTR applications that are typical of broadcast operations. It shares the robust format, durable transport and exceptional signal system of other Ampex D2 recorders. Like the other Ampex D2 recorders, it can be readily integrated into existing broadcast systems without costly signal conversion devices.

## Description

The VPR-200 accepts three standard D2 cassettes: 32-, 94- and 208-minute lengths. Thus, anything from a spot commercial to a full-length movie can be recorded, duplicated or played back on a single cassette.

With the unique and very logical control panel found on the VPR-200, operators can quickly and easily control the machine even under pressures of time. A unique control system displays machine status-at-a-glance and allows fast and easy setup. If program compression is required to fit a certain time period, the operator need only call up the appropriate display and enter the exact time reduction in seconds per hour.

## Features

- Durable, heavy-duty transport with air guides for gentle tape handling and 60X play speed in shuttle
- 20 ms lockup time from Ready Mode

- Accepts three standard D2 cassette sizes: 32, 94 and 208 minutes
- Easy-to-use control panel with logical displays for error-free operation
- Program compression capability with simple, accurate controls
- Full field store capability
- Audio metering on character generator output
- Internal audio monitoring speakers
- Read-Before-Write capability
- Quick field replacement of all wear components including heads
- Shares critical components with other Ampex VPR-200, VPR-300 and ACR-225 Series recorders, for economies of parts inventory, maintenance and training





# VPR-200

# NTSC AND PAL SPECIFICATIONS

Specification	NTSC & PAL
<u>General</u>	
Power Requirements:	50/60 Hz 90-135; 180-270 Volts, AC
Power Consumption: Avg.	1000 Watts
Operating Environment	
Temperature	5°C-40°C
Humidity	10%-90% noncondensing
Size	
Table Top	597mm H × 482mm W × 705mm D 23½" H × 19" W × 27¾" D
Rack Mount	578mm H × 432mm W × 705mm D 22¾" H × 17" × 27¾" D
Weight	114 kg (250 lbs)
<u>Recording Format</u>	
Tape Speed	SMPTE D2 131.7mm/sec
Writing Speed	27.387m/sec NTSC; 30.428m/sec PAL
Record Time	32 min. small cassette 94 min. medium cassette 208 min. large cassette
Cassette Types	D2 Series S, M, and L
Recommended Tape	Ampex 319 or equivalent 1500 Oe. metal particle tape

## Transport Characteristics

Shuttle Speed	± 7.9m/sec (60x Play)
Acceleration	3.0m/sec <sup>2</sup>
Fast Forward/ Rewind Speed	38 sec for 32 min. — S cassette 100 sec for 94 min. — M cassette 218 sec for 208 min. — L cassette
Servo Lock Times	
Color Frame P/B	20 millisecc from Ready On 1 sec from Ready Off
Tape Timer Accuracy	± 1 Frame (with continuous CTL)
Edit Accuracy	± 0 Frame

## Video

Sampling Frequency	4x FSc
Quantization	8 bits
Channel Coding	Miller <sup>2</sup>
Bandwidth	5.5 MHz ± 0.2 dB NTSC; 60 MHz ± 0.2 dB PAL 6.0 MHz - 1 dB NTSC; 6.5 MHz - 2 dB PAL
S/N	≥ 54 dB (luminance)
D.G.	≤ 2.0% (ramp with 40 IRE subcarrier)
D.φ	≤ 1.0°
K Factor	≤ 1.0% (2 T)
Y/C Delay	≤ 10 nsec (20 T)
Y/C xtalk	≤ 1.0 IRE
Moire	Not applicable
Line Tilt	≤ 0.5%
Field Tilt	≤ 1.0%
Color Gen. Lock Stability	≤ 0.2°

## Analog Multi-Generation

20 Generations (4.5 per CCIR Recommendation 500-3)

## Digital Multi-Generation

>20 Generations

Specification	NTSC & PAL
<u>Audio</u>	
Frequency Response	20 Hz - 20 kHz ± 0.5 dB
Dynamic Range	≥ 90 dB (ANSI "A" weighted, Pre-emphasis ON)
Headroom	20 dB
Distortion	≤ 0.05% (at operating level, Pre-emphasis ON) 20 Hz to 20 kHz
Crosstalk	- 80 dB (at 1 kHz)
Operating Level	- 8 dBm to + 8 dBm (1 dB increments)
Input/Output Level Range	- ∞ to + 14 dB
Wow and Flutter	Not applicable
<u>Cue</u>	
Frequency Response	300 Hz - 10 kHz ± 2.0 dB
S/N	≥ 44 dB
Distortion	≤ 1.0% (1 kHz @ operating level)
Operating Level	- 8 dBm to + 8 dBm (1 dB increments)
<u>Signal Inputs</u>	
<u>Video</u>	
Analog	0.5 V to 2.0 V p-p (75 Ω BNC)
Digital	SMPTE proposed RP 125X, parallel interface
Reference	Composite (Video or Black Burst) (High impedance bridging, BNC)
<u>Audio</u>	
Analog	Max. + 28 dBm (50k Ω) Balanced, + 22 dBm Unbalanced (<30 Ω)
Digital	SMPTE proposed RP 4.40 - X, parallel interface
Optional	AES/EBU format
Cue	Max. + 28 dBm (50k Ω)
Timecode	2.4 V ± 1.4 V p-p (10k Ω)
<u>Signal Outputs</u>	
<u>Video</u>	
Analog	2 each @ 1.0 Volt p-p (75 Ω BNC)
Digital	SMPTE proposed RP 125X
<u>Audio</u>	
Analog	Max. + 28 dBm Balanced + 22 dBm, Unbalanced (<50 Ω)
Digital	SMPTE proposed RP 4.40 - X
Optional	AES/EBU format
Cue	Max. + 14 dBm Balanced, + 8 dBm Unbalanced (<50 Ω)
Timecode	2.4 Volt p-p (<300 Ω)
Character Video	1.0 Volt p-p (75 Ω BNC)
Waveform Monitor	1.0 Volt p-p (75 Ω BNC)
Picture Monitor	1.0 Volt p-p (75 Ω BNC)
Headphones	300 milliwatt (150 Ω)
Audio Monitor	- 16 dBμ (100 Ω source)
<u>Remotes</u>	
RS-422	2 each, 9 pin D, SMPTE
RS-232	2 each, 25 pin D, Serial
GPI	1 each, 25 pin D, Parallel

Specifications subject to change without notice or obligation.





# VPR-250 D2 FORMAT COMPOSITE DIGITAL RECORDER

## General

The VPR-250 recorder is a D2 format composite digital machine especially adapted for the various VTR applications that are typical of broadcast operations. It shares the robust format, durable transport and exceptional signal system of other Ampex D2 recorders. Like the other Ampex D2 recorders, it can be readily integrated into existing broadcast systems without costly signal conversion devices.

## Description

The VPR-250 accepts two standard D2 cassettes: 32-, and 94-minute lengths. For applications that do not require longer record/play times, the VPR-250 is a very cost-effective choice.

With the unique and very logical control panel found on the VPR-250, operators can quickly and easily control the machine even under pressures of time. A unique control system displays machine status-at-a-glance and allows fast and easy setup. If program compression is required to fit a certain time period, the operator need only call up the appropriate display and enter the exact time reduction in seconds per hour.

## Features

- Durable, heavy-duty transport with air guides for gentle tape handling and 60X play speed in shuttle
- 20 ms lockup time from Ready Mode
- Accepts two standard D2 cassette sizes: 32 and 94 minutes
- Easy-to-use control panel with logical displays for error-free operation
- Program compression capability with simple, accurate controls
- Full field store capability
- Audio metering on character generator output
- Internal audio monitoring speakers
- Read-Before-Write capability
- Quick field replacement of all wear components including heads
- Shares critical components with other Ampex VPR-200, VPR-300 and ACR-225 Series recorders, for economies of parts inventory, maintenance and training





# VPR-250

# NTSC AND PAL SPECIFICATIONS

Specification	NTSC and PAL
<u>General</u>	
Power Requirements:	50/60 Hz 90-135; 180-270 Volts, AC
Power Consumption:	
Avg.	1000 Watts
<u>Operating Environment</u>	
Temperature	5°C-40°C
Humidity	10%-90% noncondensing
<u>Size</u>	
Table Top	597mm H × 482mm W × 705mm D 23 <sup>1</sup> / <sub>2</sub> " H × 19" W × 27 <sup>3</sup> / <sub>4</sub> " D
Rack Mount	578mm H × 432mm W × 705mm D 22 <sup>3</sup> / <sub>4</sub> " H × 17" × 27 <sup>3</sup> / <sub>4</sub> " D
Weight	114 kg (250 lbs)
<u>Recording Format</u>	
Tape Speed	SMPTE D2 131.7mm/sec
Writing Speed	27.387m/sec NTSC; 30.428 m/sec PAL
Record Time	32 min. small cassette 94 min. medium cassette
Cassette Types	D2 Series S and M
Recommended Tape	Ampex 319 or equivalent 1500 Oe. metal particle tape
<u>Transport Characteristics</u>	
Shuttle Speed	± 7.9m/sec (60x Play)
Acceleration	3.0m/sec <sup>2</sup>
Fast Forward/ Rewind Speed	38 sec for 32 min. — S cassette 100 sec for 94 min. — M cassette
Servo Lock Times	
Color Frame P/B	20 millisecc from Ready On 1 sec from Ready Off
Tape Timer Accuracy	± 1 Frame (with continuous CTL)
Edit Accuracy	± 0 Frame
<u>Video</u>	
Sampling Frequency	4FSc
Quantization	8 bits
Channel Coding	Miller <sup>2</sup>
Bandwidth	5.5 MHz ± 0.2 dB NTSC; 6.0 MHz ± 0.2 dB PAL 6.0 MHz - 1 dB NTSC; 6.5 MHz - 1 dB PAL
S/N	≥54 dB (luminance)
D.G.	≤2.0% (ramp with 40 IRE subcarrier)
D.φ	≤1.0°
K Factor	≤1.0% (2 T)
Y/C Delay	≤10 nsec (20 T)
Y/C xtalk	≤1.0 IRE
Moire	Not applicable
Line Tilt	≤0.5%
Field Tilt	≤1.0%
Color Gen. Lock Stability	≤0.2°
<u>Analog Multi-Generation</u>	
20 Generations (4.5 per CCIR Recommendation 500-3)	
<u>Digital Multi-Generation</u>	
>20 Generations	

Specification	NTSC and PAL
<u>Audio</u>	
Frequency Response	20 Hz - 20 kHz ± 0.5 dB
Dynamic Range	≥90 dB (ANSI "A" weighted, Pre-emphasis ON)
Headroom	20 dB
Distortion	≤0.05% (at operating level, Pre-emphasis ON)
Crosstalk	20 Hz to 20 kHz - 80 dB (at 1 kHz)
Operating Level	- 8 dBm to + 8 dBm (1 dB increments)
Input/Output Level Range	- ∞ to + 14 dB
Wow and Flutter	Not applicable
<u>Cue</u>	
Frequency Response	300 Hz - 10 kHz ± 2.0 dB
S/N	≥44 dB
Distortion	≤1.0% (1 kHz @ operating level)
Operating Level	- 8 dBm to + 8 dBm (1 dB increments)
<u>Signal Inputs</u>	
<u>Video</u>	
Analog	0.5 V to 2.0 V p-p (75 Ω BNC)
Digital	SMPTE proposed RP 125X, parallel interface
Reference	Composite (Video or Black Burst) (High impedance bridging, BNC)
<u>Audio</u>	
Analog	Max. + 28 dBm (50k Ω) Balanced, + 22 dBm Unbalanced (<30 Ω)
Digital	SMPTE proposed RP 4.40 - X, parallel interface
Optional	AES/EBU format
Cue	Max. + 28 dBm (50k Ω)
Timecode	2.4 V ± 1.4 V p-p (10k Ω)
<u>Signal Outputs</u>	
<u>Video</u>	
Analog	2 each @ 1.0 Volt p-p (75 Ω BNC)
Digital	SMPTE proposed RP 125X
<u>Audio</u>	
Analog	Max. + 28 dBm Balanced + 22 dBm Unbalanced (<50 Ω)
Digital	SMPTE proposed RP 4.40 - X
Optional	AES/EBU format
Cue	Max. + 14 dBm Balanced, + 8 dBm Unbalanced (<50 Ω)
Timecode	2.4 Volt p-p (<300 Ω)
Character Video	1.0 Volt p-p (75 Ω BNC)
Waveform Monitor	1.0 Volt p-p (75 Ω BNC)
Picture Monitor	1.0 Volt p-p (75 Ω BNC)
Headphones	300 milliwatt (150 Ω)
Audio Monitor	- 16 dBμ (100 Ω source)
<u>Remotes</u>	
RS-422	2 each, 9 pin D, SMPTE
RS-232	2 each, 25 pin D, Serial
GPI	1 each, 25 pin D, Parallel

Specifications subject to change without notice or obligation.





# RCP-200 REMOTE CONTROL PANEL FOR D2 FORMAT RECORDERS

## General

The RCP-200 remote control panel is a digital controller designed to operate with all Ampex D2 recorders. In conjunction with a picture monitor and a waveform monitor/vectorscope, the RCP-200 provides a simple and cost-effective system for monitoring and adjusting the input and output parameters of up to four VTRs.

## Description

The RCP-200 control panel is a single rack height unit that controls the input/output video *and audio* functions of up to four machines. Remote machine control is accomplished by using ACE SMPTE protocol over the RS 422 interface. Audio and video operational adjustments are available on dedicated

center return potentiometers. All four digital audio channels can be precisely adjusted by monitoring signal levels, using the on-screen audio bargraph display that is a feature of Ampex D2 machines. Video adjustments are simplified by the provision of separately lighted unity buttons for each function. Additionally, the RCP-200 control panel accepts and produces general purpose interface (GPI) inputs and outputs to simplify interconnection with external signal routing and monitoring devices.

## Features

- Will select and control up to four VPR-200 or VPR-300 Series VTRs.
- Combines audio and video adjustments on a single panel.

- Easy to operate, straightforward controls.
- Simple knob-per-function human interface with separate unity settings.
- Easy systems integration with master/slave machine switching capability.
- GPI interface designed for direct control of waveform monitor input switching.
- Compact size (1 rack unit high) permits convenient installation in monitor bridges or with rack mounted equipment.
- Universal power supply with detachable power cord for easy installation.

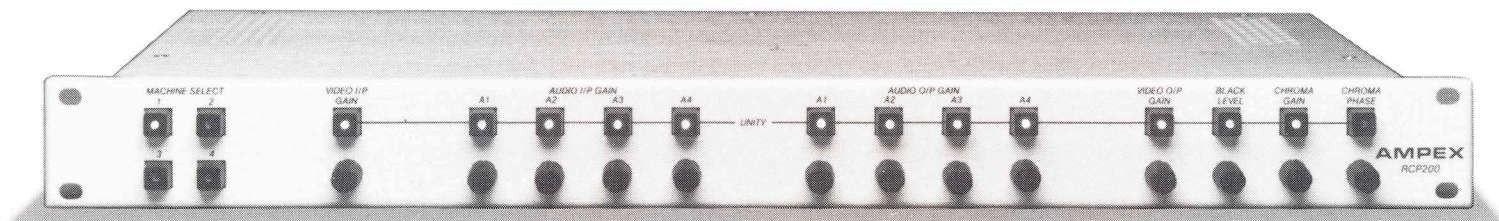

## Range of Control (of a VPR-200 or VPR300 Series VTR)

---

### VIDEO

Input Signal (Analog)	
Video Gain	± 6 dB
Output Signal (Analog/Digital)	
Video Gain	Off to +3 dB
Chroma Gain	Off to +3 dB
Black Level	± 10 IRE (NTSC) ± 10% (PAL)
Output Signal (Analog)	
Chrominance Phase	± 20 degrees

### AUDIO (Control of four (4) digital channels)

Input Signal (Analog)	
Audio Gain	Off to +14 dB
Output Signal (Analog/Digital)	
Audio Gain	Off to +14 dB

### PHYSICAL CHARACTERISTICS

#### Chassis Dimensions

Height:	1.70" (43 mm) (1 Rack unit high)
Width:	17.5" (441 mm) (1 Rack unit wide)
Depth:	8" (202 mm)

NOTE: The unit is designed for rack mounting with front access. It is secured in the rack with rack ears and standard mounting holes, which are integral parts of the unit.

### OPERATING CONDITIONS

Temperature	0-45 degrees C
Humidity	5-95% RH (non-Condensing)

### POWER REQUIREMENTS

Input Power Requirements	Worldwide 50/60 Hz standards without reconfiguration
Power Consumption	Less than 20 watts

### INPUT/OUTPUT SIGNALS

#### Machine Control:

No. of machines controlled	Up to four (4) recorders can be controlled by four (4) separate connectors
Machine Communications	All VTR serial control is carried out over an EIA standard RS-422 interconnection system. ACE SMPTE protocol is used for message transfer.

### GPI INTERFACE

Connector	A single 25 pin sub-miniature D type connector
Pin Assignment	See Installation Manual

---

Specifications subject to change without notice or obligation.

